

FORMING THE FUTURE



RAILWAY

Forging systems for the railway industry

SCHULER 

Member of the ANDRITZ GROUP

FORMING THE FUTURE

FORGING SYSTEMS FOR THE RAILWAY INDUSTRY. ON THE RIGHT TRACK.





Use of forgings in automatic couplings.

All over the world, a high-capacity railway network brings people together. Once on the move, they rely upon technology to function properly. Whether wheels, rail ends, switches or chassis screw connections for high-speed trains, Schuler provides comprehensive technical expertise in forging technology to make sure that everything runs smoothly.

With 175 years of experience and approximately 5,500 employees working at international sites in Europe, the USA, Mexico, Brazil, Thailand, India, China and Russia, Schuler offers extensive know-how, competent expertise as well as customer-oriented services.

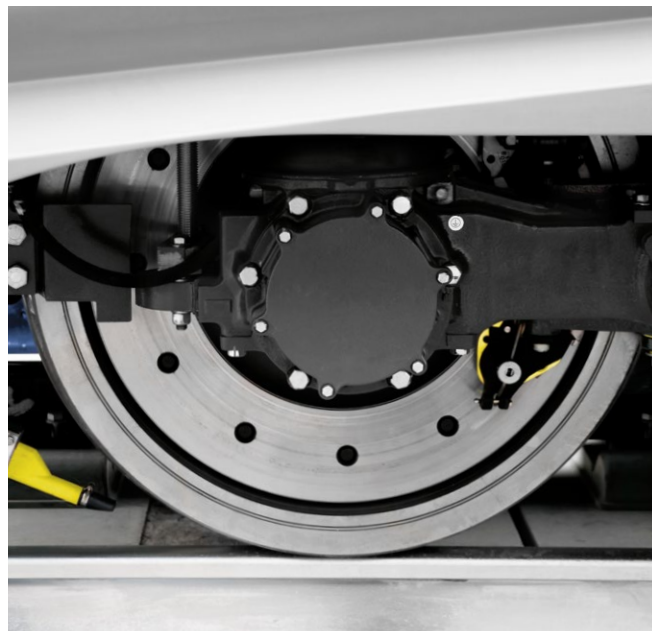

Forged and rolled high-speed wheel.

We offer you innovative and reliable solutions. Work with us to stay on track in the growing global transport technology market.

Schuler system solutions for a wide range of parts

- Railway wheels
- Axles
- Crankshafts
- Large and small connecting rods
- Disk brakes
- Chassis components
- Connection couplings
- Sleeper screws

HYDRAULIC TURNKEY SYSTEMS. FORGING AND ROLLING RAILWAY WHEELS.



Hydraulic press for forging railway wheels.



Schuler Wheel Roller MHRV 180/80.

High speeds, extreme loads, powerful accelerations and sharp emergency braking – only forged railway wheels can meet these requirements. Railway wheels are forged in four working steps before they undergo mechanical machining. First of all, a disk-shaped preform is produced in two stages from a heated block. This preform is then rolled out into the final contour using a wheel roller. Finally, the rolled-out wheel is calibrated and the hub is offset axially and pierced. Hydraulic presses with a press force up to 100,000 kN are used for preforming of the wheels. Generally, press forces from 20,000 to 50,000 kN are required for flanging and piercing.



Glowing railway wheel after rolling.

Advantages

- Precise preforming by high press forces, for high precision in the areas of the hub and running rim
- Weight saving by high accuracy in presses and wheel roller
- High productivity and availability
- Quick and easy retooling of the entire machine
- Standardized operating concept of the presses and wheel roller

Applications

- Railway wheels for freight cars
- Railway wheels for locomotives and cabooses
- Crane wheels

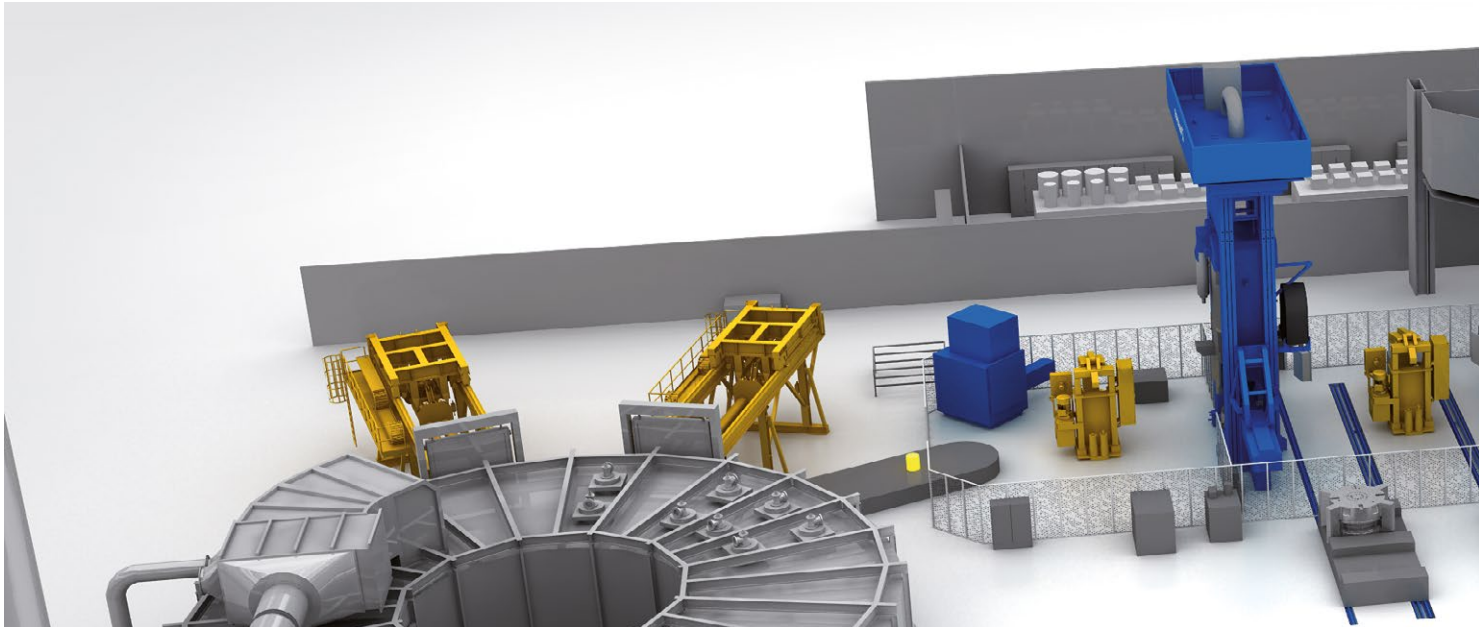

Automated turnkey machine for manufacturing railway wheels with rotary hearth furnace, three hydraulic forging presses and the Schuler wheel roller.

FORGING AND ROLLING RAILWAY WHEELS IN A COMPLETE SYSTEM

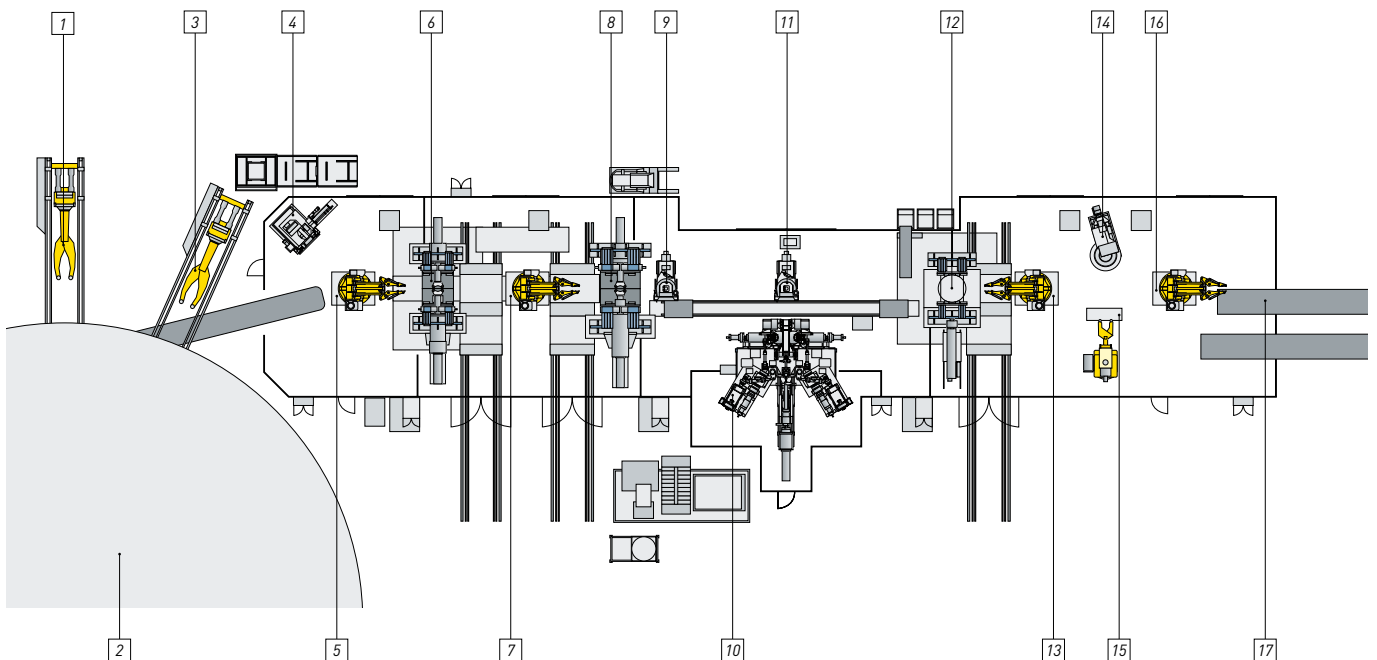

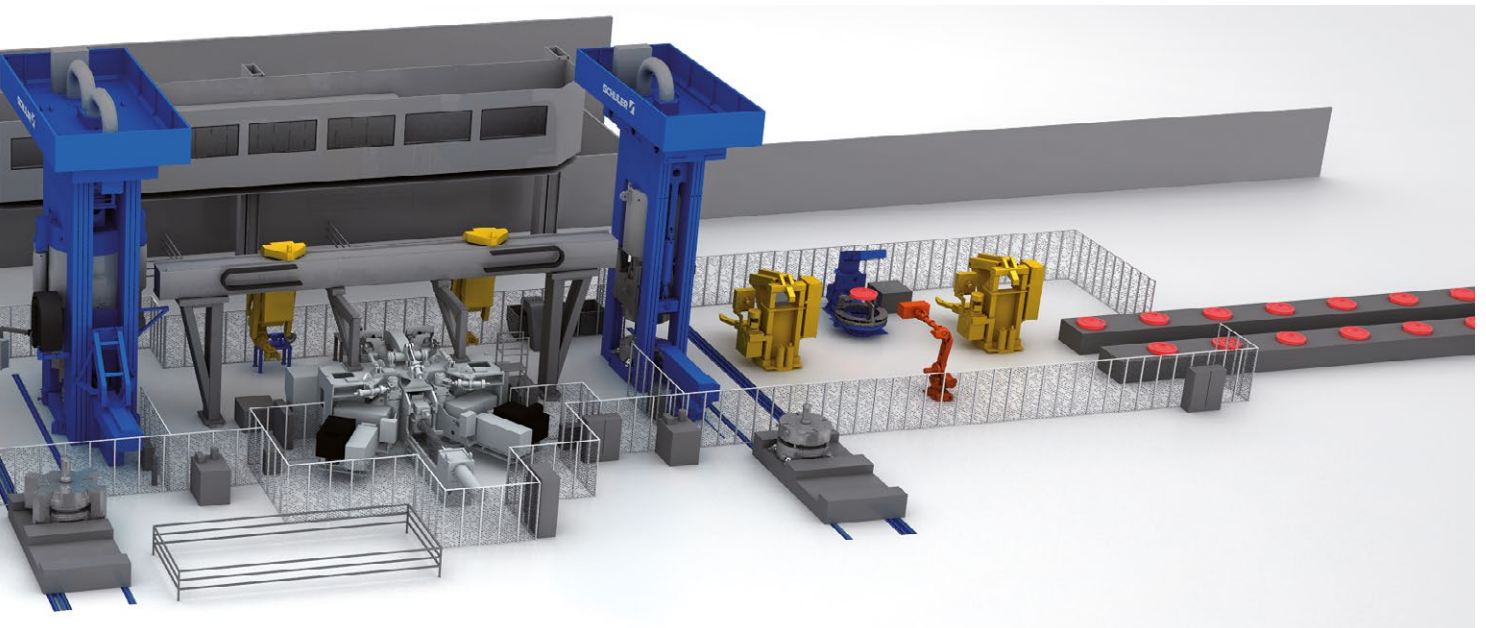

-
- 1 Loading robot
 - 2 Rotary hearth furnace
 - 3 Unloading robot
 - 4 Descaling
 - 5 Robot
 - 6 Hydraulic forging press with 50,000 kN
 - 7 Robot
 - 8 Hydraulic forging press with 100,000 kN
 - 9 Manipulators
 - 10 Wheel roller
 - 11 Manipulators
 - 12 Hydraulic piercing and crimping press with 50,000 kN
 - 13 Robot
 - 14 Laser measuring system
 - 15 Marking
 - 16 Robot
 - 17 Exit conveyors
-

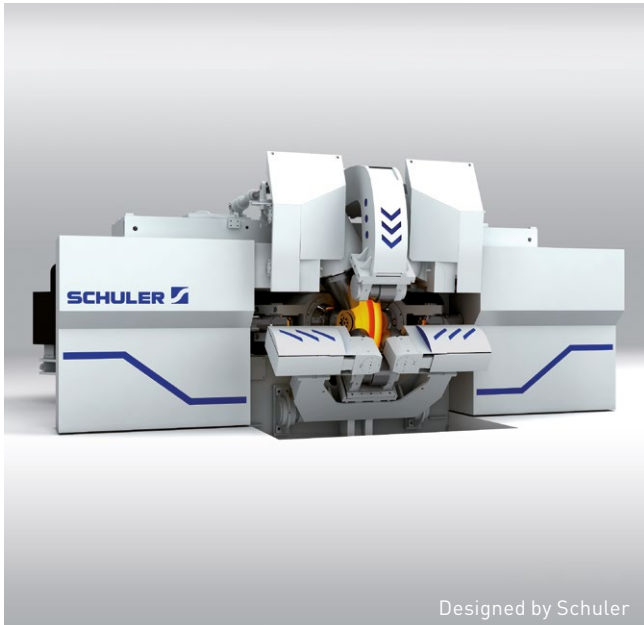

Designed by Schuler

The Schuler wheel roller MHRV-180/80.

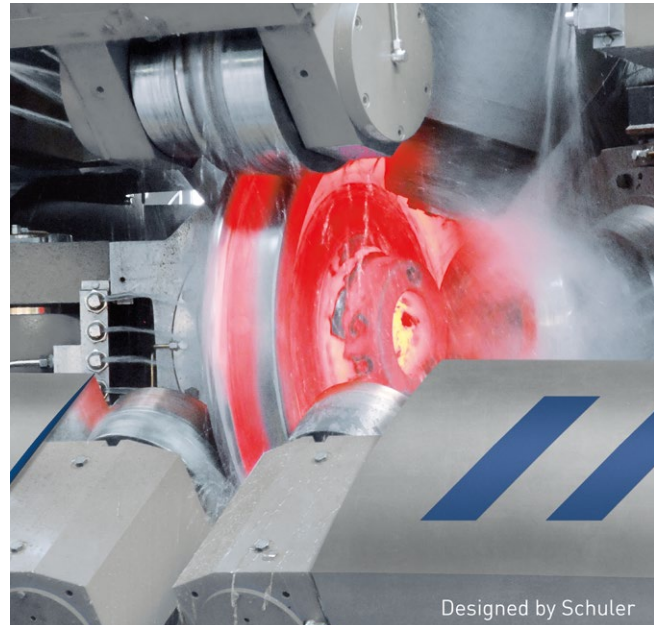

Designed by Schuler

Rolling a freight car wheel on the wheel roller.

THE SCHULER WHEEL ROLLER.

A central unit of the forging line is the wheel roller which reflects the full range of Schuler's expertise in the areas of mechanical, hydraulic and electrical systems: Its extremely rigid configuration, large bearing dimensions and axes equipped with primary and secondary drives guarantee reliable operation and high availability.

The precise control hydraulics of the individual axes ensure that the rolled wheels satisfy the most exacting quality requirements. A comprehensive visualization concept for the press and wheel roller makes it easy to operate the machine. The control systems of the press and wheel roller have the same design, thus facilitating maintenance and diagnosis.

SEQUENCE OF OPERATIONS FOR FORGING AND ROLLING RAILWAYS WHEELS

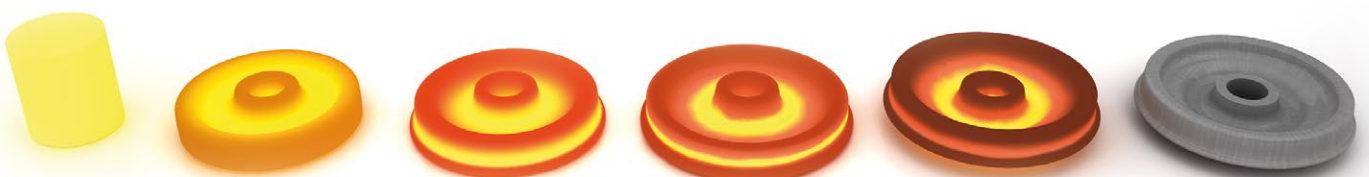

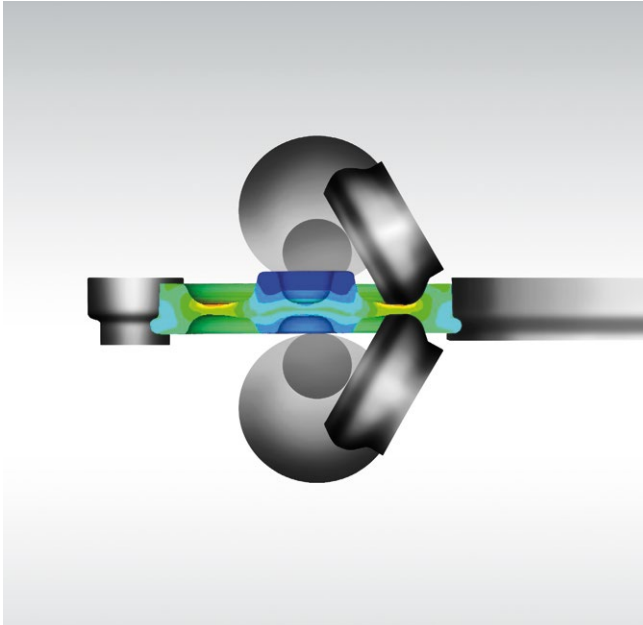

Simulation of the rolling process.

JOB ENGINEERING SOFTWARE JES.

In order to design the forging and rolling process, the machine control is supplemented by a simulation program: Job Engineering Software JES. The process plan and the die contour for the particular wheel are calculated starting from the wheel geometry. A link to the machine controller allows the corresponding machine parameters and the rolling strategy to be taken into account when calculating the process program.



Forces in the sequence of the rolling process.

Then, the parameters calculated in the JES (position, speeds and movements of all axes) for the wheel to be produced are sent to the machine control of the presses and the wheel roller.

An FEM analysis simulating the entire process for the product makes it possible to check the process via a direct connection to the JES. Insights gained from this are returned directly to the JES, thereby making it possible to optimize the entire process.

ENGINEERING ENVIRONMENT FOR CONFIGURING AND OPTIMIZING THE FORGING AND ROLLING PROCESS

A technology partnership with Simufact enables Schuler to offer a full simulation of complete process sequences. Schuler provides the process expertise while Simufact contributes its many years of experience in the area of process simulation for complex forming processes.



OPEN DIE FORGING SYSTEMS. MANUFACTURING RAILWAY AXLES.

Railway axles are components exposed to significant loads that place specific requirements on the forging process. They are manufactured in one step from square or round-profile blanks, referred to as ingots, and are transported to the forging manipulator using an ingot cart running on tracks. The manipulator takes them from the cart and places them into the hydraulic open-die forging press for the forging process. The movements of the press and manipulator are synchronized by the press control.

The forging cell is equipped with a high-performance, robust direct drive for high stroke rates and reliable operation. If a second manipulator is used as well, there is no need to turn the forgings. This results in much shorter cycle times. Also, two axles can be forged from one blank, further boosting productivity.

Advantages

- High repeat accuracy
- High reliability
- Automatic forging die change
- Maximum efficiency even with small batches
- High flexibility



Open die forging press in push down design.

Applications

- Railway axle

FORGING LINE FOR MANUFACTURING RAILWAY AXLES

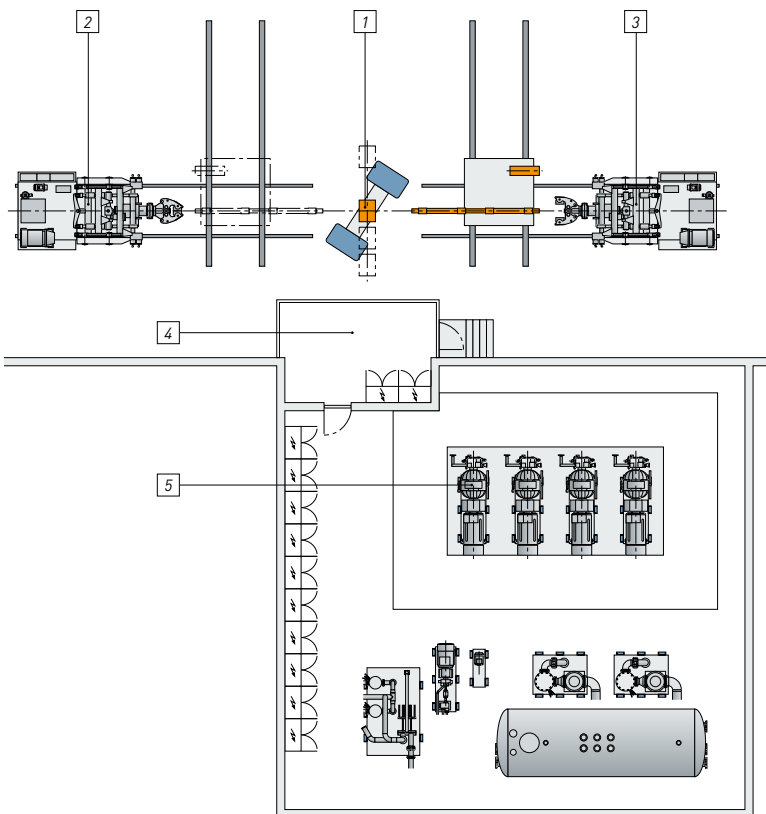

- 1 Open-die forging press
- 2 Manipulator 1
- 3 Manipulator 2
- 4 Operator station
- 5 Hydraulic drive

TECHNICAL DATA OF OPEN-DIE FORGING PRESSES

Types	MHFT	MHFU
Design	Pushdown	Pulldown
Press force [kN]	800–1,500	800–1,500
Die change	Lateral shifting device for automatic change of the forging dies	Lateral shifting device for automatic change of the forging dies
Drive	Energy-efficient direct drive with servo-controlled hydraulic pumps	Energy-efficient direct drive with servo-controlled hydraulic pumps
Material feed	Ingot cart with integrated turntable	Ingot cart with integrated turntable
Material handling	Forging manipulators	Forging manipulators

COMPLETE SYSTEMS WITH ECCENTRIC PRESS AND THREAD ROLLING. MANUFACTURING SLEEPER SCREWS.



The mechanical press is the main component of the complete system for manufacturing sleeper screws.

Sleeper screws are manufactured in three production steps, in large quantities from wire coils. These screws have a variety of unique head and thread designs. During production, the wire section is first cut into sections with a precisely defined length. In the next production step, part of this cut wire is inductively heated and the screw head is forged in the eccentric press. The third machine rolls the thread, which also involves heating part of the blank using an induction system.

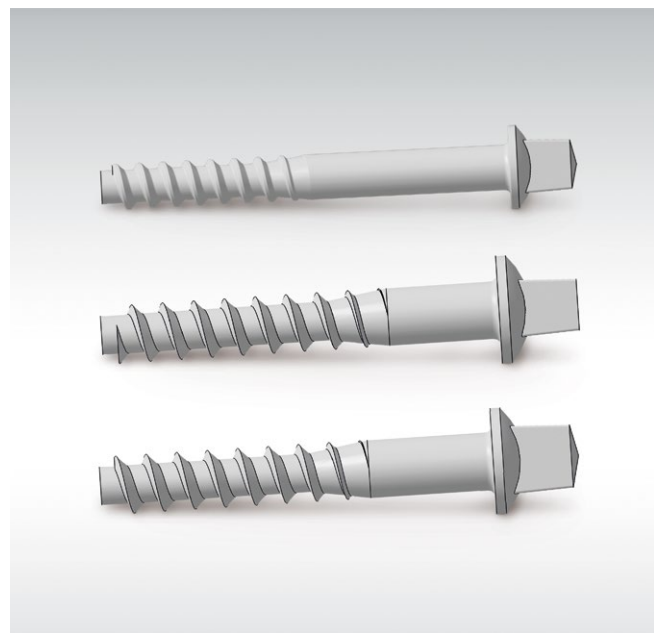

Typical shapes of sleeper screw.

Applications

- Sleeper screws with a wide range of shapes

Advantages

- Wide range of head and thread shapes
- High output
- Flexible production cells
- Maximum efficiency

COMPLETE SYSTEM FOR MANUFACTURING SLEEPER SCREWS WITH SCHULER ECCENTRIC PRESS

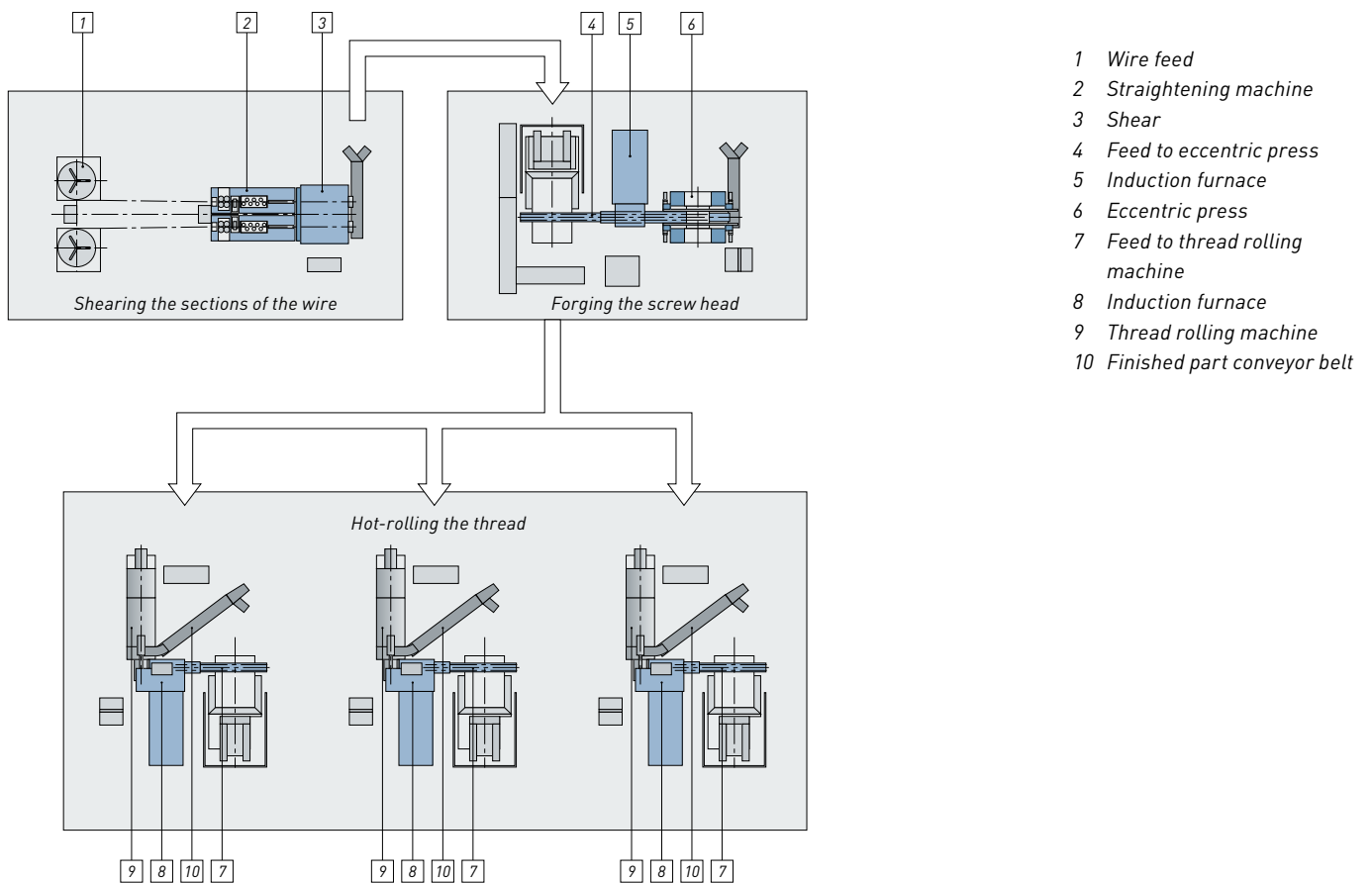

TECHNICAL DATA OF ECCENTRIC PRESSES

Types	MME1-250	MME1-315	MME1-400
Press force [kN]	2,500	3,150	4,000
Drive	Mechanical drive	Mechanical drive	Mechanical drive
Material feed	Automatic	Automatic	Automatic
Component transfer	Tri-axis transfer	Tri-axis transfer	Tri-axis transfer
Output	approx. 30 parts / minute	approx. 30 parts / minute	approx. 30 parts / minute
Forming stations	3	3	3

COMPLETE SYSTEMS WITH SCREW PRESS. FORGING BRAKE DISKS, CRANKSHAFTS, CONRODS OR LARGE CONRODS.



Screw press with hydraulic trimming press on one forging line.

Thanks to almost 120 years of experience in building screw presses, with continuous developments, there is practically no drop forging that cannot be manufactured using a screw press. As far back as 1936, the conventional friction drive was superseded by the friction roller drive and, subsequently, direct drive. In this direct drive, the torque from the drive motor is transmitted to the screw without intermediate drive components, wear parts or energy losses. This drive concept represents the optimum design solution for a screw press drive – in terms of robustness, reliability, maintenance and efficiency.



Forged brake disk.

Applications

- Crankshafts
- Conrod / large conrod
- Brake disks

Advantages

- Wide range of parts
- High repeat accuracy
- High reliability
- High flexibility
- Maximum efficiency
- Frequency Drive
- Suitable for automation and line integration

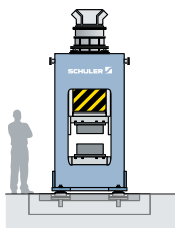

PA 125 – PA 360
PAR 180 – PAR 360

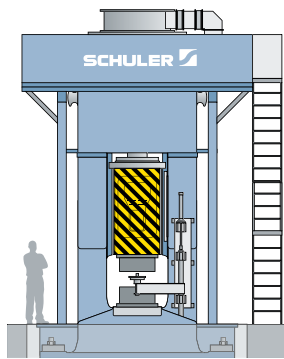

PSM 265 – PSM 630
PSH 265 – PSH 630

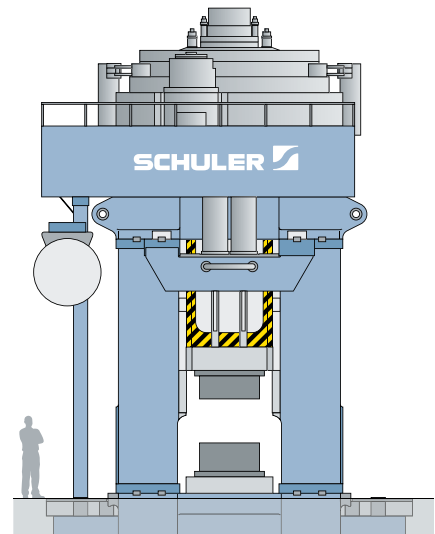

PZS 710 – PZS 1325

TECHNICAL DATA OF SCREW PRESSES

Types	PA	PAR	PSM	PSH	PZS
Screw diameter [mm]	125–360	180–360	265–630	265–630	710–1,325
Gross working capacity [kJ]	4.5–100	24–170	65–700	90–1,000	1,150–10,000
Continuously permitted press force [kN]	2,500–21,000	5,000–21,000	11,000–64,000	11,000–64,000	80,000–280,000
Die-to-die blow force [kN]	3,200–26,000	6,300–26,000	14,000–80,000	14,000–80,000	100,000–360,000

FORGING SYSTEMS WITH COUNTERBLOW HAMMERS. FORGING BRAKE DISKS, CRANKSHAFTS, CONRODS OR LARGE CONRODS.



Counterblow hammer with 800 kJ working capacity.

Counterblow hammers are predominantly used for manufacturing large and ultra-large forgings. The high impact energy and tonnage of the hammer dies, moving in opposite directions, permits precision forming of large forgings.

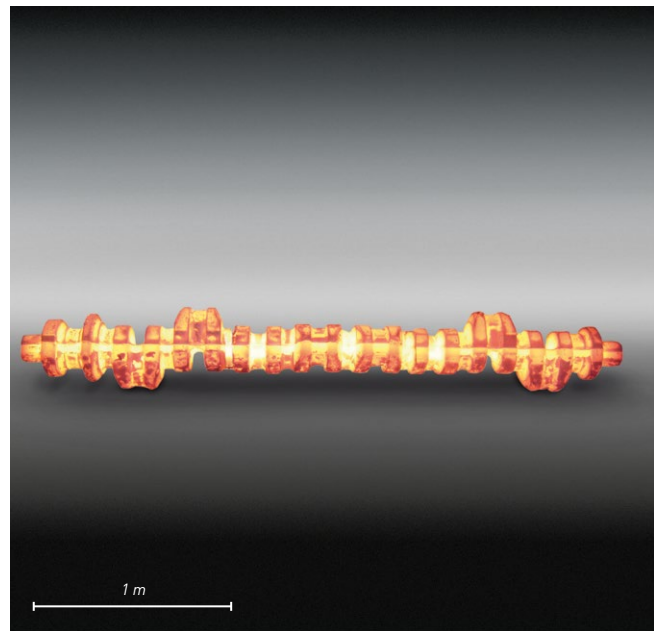

Large crankshaft forged on a counterblow hammer.

Applications

- Crankshafts
- Large connecting rod
- Chassis components
- Connection couplings

Advantages

- Extremely high impact energy and tonnage
- High reliability and availability
- High stability of the overall structure
- High precision with large forgings
- Hydraulic tup coupling
- Long stroke for accessibility

FORGING LINE WITH COUNTERBLOW HAMMER, TRIMMING AND CALIBRATING PRESS

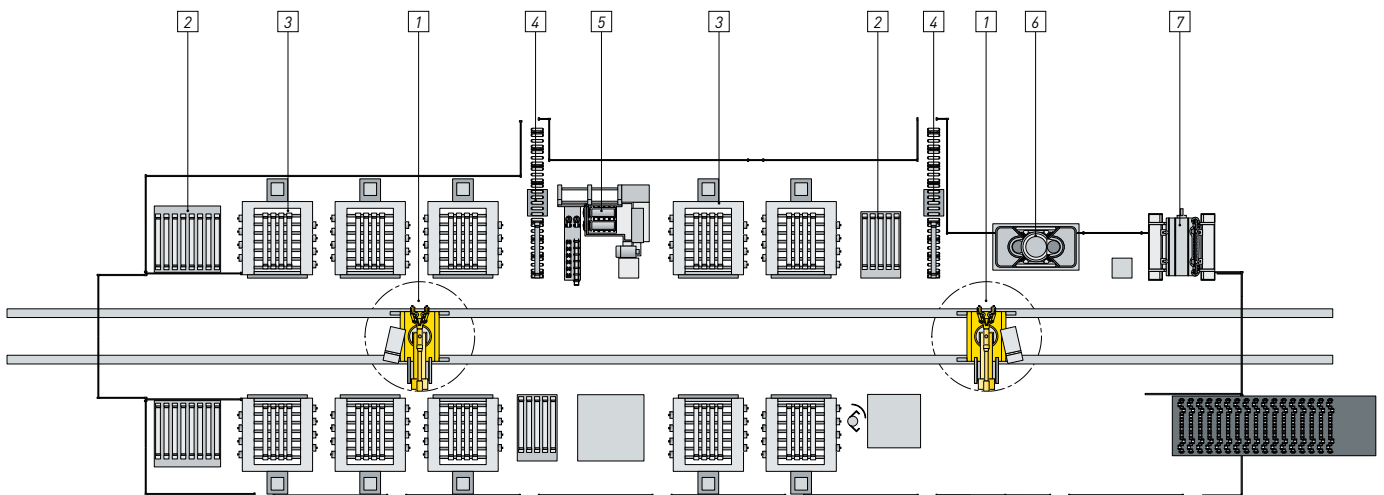

- 1 Manipulator
- 2 Storage area
- 3 Furnace
- 4 Descaling
- 5 Drop machine
- 6 Counterblow hammer
- 7 Trimming and calibrating press

TECHNICAL DATA OF COUNTERBLOW HAMMERS

Types	HG	DG
Working capacity [kJ]	160 – 400	160 – 1,400
Drive	Hydraulic drive	Pneumatic drive
Coupling of the tups	Hydraulic slide coupling	Hydraulic slide coupling
Material feed /material handling	Forging manipulators	Forging manipulators

LIFECYCLE SERVICE FROM SCHULER.
EXTENSIVE INDUSTRY SERVICES FOR
FORMING TECHNOLOGY.



From the dependable supply of spare parts and rapid assistance in the event of malfunctions to the digital transformation process: products and services from Schuler Service help you to keep your system running at an optimal level.

Whether it's spare parts service, maintenance work, modernisations, used presses, IT solutions, or our 24/7 support with quick response times: you can count on our Service Team to ensure maximum safety and system availability in your press shop – whenever you need us, even on our 24/7 Hotline.

Our experts provide you with the right solutions over the entire lifecycle of your system whilst assisting you with digital transformation, from consultations about various available IT solutions to the actual implementation.

Schuler Service is here to help as your competent partner. Reliable, knowledgeable and friendly.

**We look forward to hearing from you.
Your Service Team.**

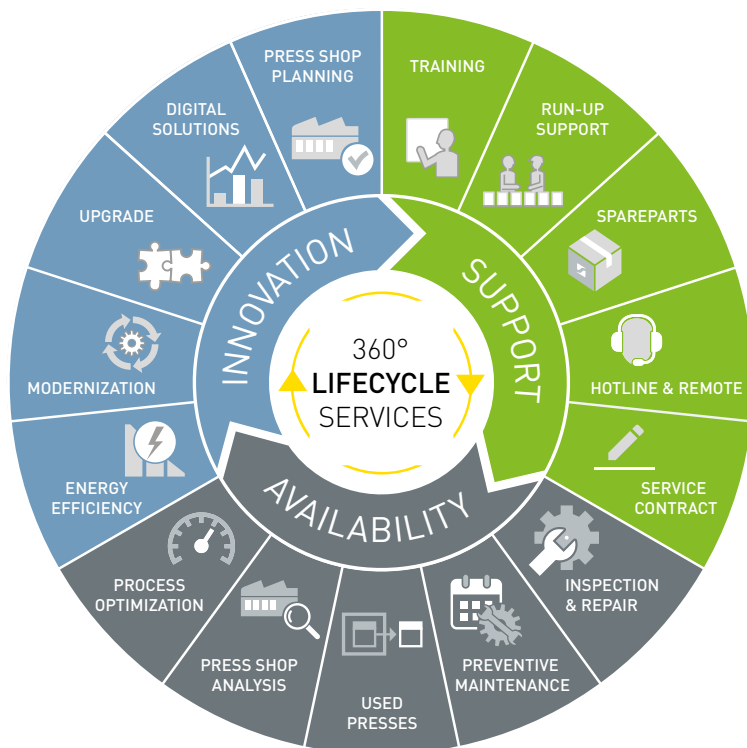

www.schulergroup.com/service_en

ABOUT THE SCHULER GROUP – WWW.SCHULERGROUP.COM

Schuler offers customized cutting-edge technology in all areas of forming – from the networked press to press shop planning. In addition to presses, our products include automation, dies, process know-how and service for the entire metalworking industry. Schuler's Digital Suite brings together solutions for networking forming technology and is continuously being developed to further improve line productivity and availability. Our customers include automotive manufacturers and suppliers, as well as companies in the forging, household appliance and electrical industries. Presses from the Schuler Group mint coins for more than 180 countries. Founded in 1839 at our headquarters in Göppingen, Germany, Schuler has approx. 5,000 employees at production sites in Europe, China and the Americas, as well as service companies in more than 40 countries. The company is part of the international technology group ANDRITZ.

Service center forging hammers

Schuler Pressen GmbH

Wetzlarer Straße 1
57250 Netphen-Werthenbach
Germany
Phone +49 2737 962-300

Mechanical presses for cold, warm and hot forging

Schuler Pressen GmbH

Schussenstraße 11
88250 Weingarten
Germany
Phone Sales +49 751 401-2214

Hydraulic presses for cold, warm and hot forging

Schuler Pressen GmbH

Louis-Schuler-Straße 9
75050 Gemmingen
Germany
Phone + 49 7267 809-0

Phone Service +49 7161 66-628
forging@schulergroup.com
www.schulergroup.com/railway



www.schulergroup.com/
railway

