

FORMING THE FUTURE





MECHANICAL FORGING PRESSES WITH ECCENTRIC DRIVE

MME/MSE. MECHANICAL FORGING PRESSES WITH ECCENTRIC DRIVE.

In the manufacture of forged parts reliability and high flexibility are required.



Schuler forging. System solutions from Schuler offer customers all over the world a decisive quality advantage in all temperature ranges:

-  Systems for hot forging
-  Systems for warm forging
-  Systems for cold forging

Schuler mechanical multi-station presses with eccentric drive are primarily used in warm forging.

High production flexibility, fast response times and efficiency in the production of standard parts are becoming increasingly important. With the systems engineering of Schuler this is possible – and even more.

The press series MME/MSE was optimized in terms of set-up times and net performance and impresses with outstanding component quality – even the most demanding challenges. The user benefits from cost reductions, output and a decisive extra flexibility.

All this becomes possible only with the optimal coordination of the equipment, process technology know-how, and tool technology. Thanks to this comprehensive approach and many years of experience Schuler offers complete customer solutions with the press series MME/MSE which provide the highest efficiency levels in the following areas:

- Warm forging (for part temperatures of 550 to 950°C) and
- Hot forging (for part temperatures of 950 to 1,200°C)

Thanks to the design of the presses and different processing methods:

- A wide spectrum of different part geometries can be produced (at nominal press forces of 2,500 kN to 20,000 kN) and
- optimal part quality can be produced with long tool service life.
- Moreover, the MME/MSE press series is designed to be low-maintenance and extremely user friendly.

The advantages:

- High output rates
- Optimal quality
- Wide range of parts
- Long stroke length
- Minimum contact times
- Extended non-contact times for die cooling
- Long die life
- Large die space
- Tight component tolerances and high component quality
- Optional servo drive



Eccentric drive press MME2-1200.

A wide spectrum of parts and high production rates. With nominal press forces of 2,500 kN to 20,000 kN the widest possible range of part geometries can be produced using warm and hot forging. The sophisticated drive kinematics and high-performance bed-side and slide-side ejectors offer the ideal conditions for reliable part handling and high production rates.

Optimum part quality and long tool service life. The press frame is an extremely rugged, welded design. Its compact construction and 2-point slide suspension permit high rigidity and high levels of eccentric loading. The features and the extraordinarily precise Schuler slide guiding represent the highest standards for achieving both excellent part quality and long tool service life.



Eccentric drive press MME2-2000.

The generously dimensioned die space offers sufficient space to incorporate complex multi-station dies with 5-6 forming stations. This large number of forming stations permits greater precision in the forming of complex geometries. By means of an optional sizing/calibrating operation even narrower part tolerances can be achieved.

For parts which require only one or two forming operations there are also compact presses available with 1-point slide suspension.

Low maintenance and user-friendly. Design, execution and the control software of the MME/MSE press series are extremely user-friendly. This ensures short start-up and changeover times as well as less time required for service and maintenance.

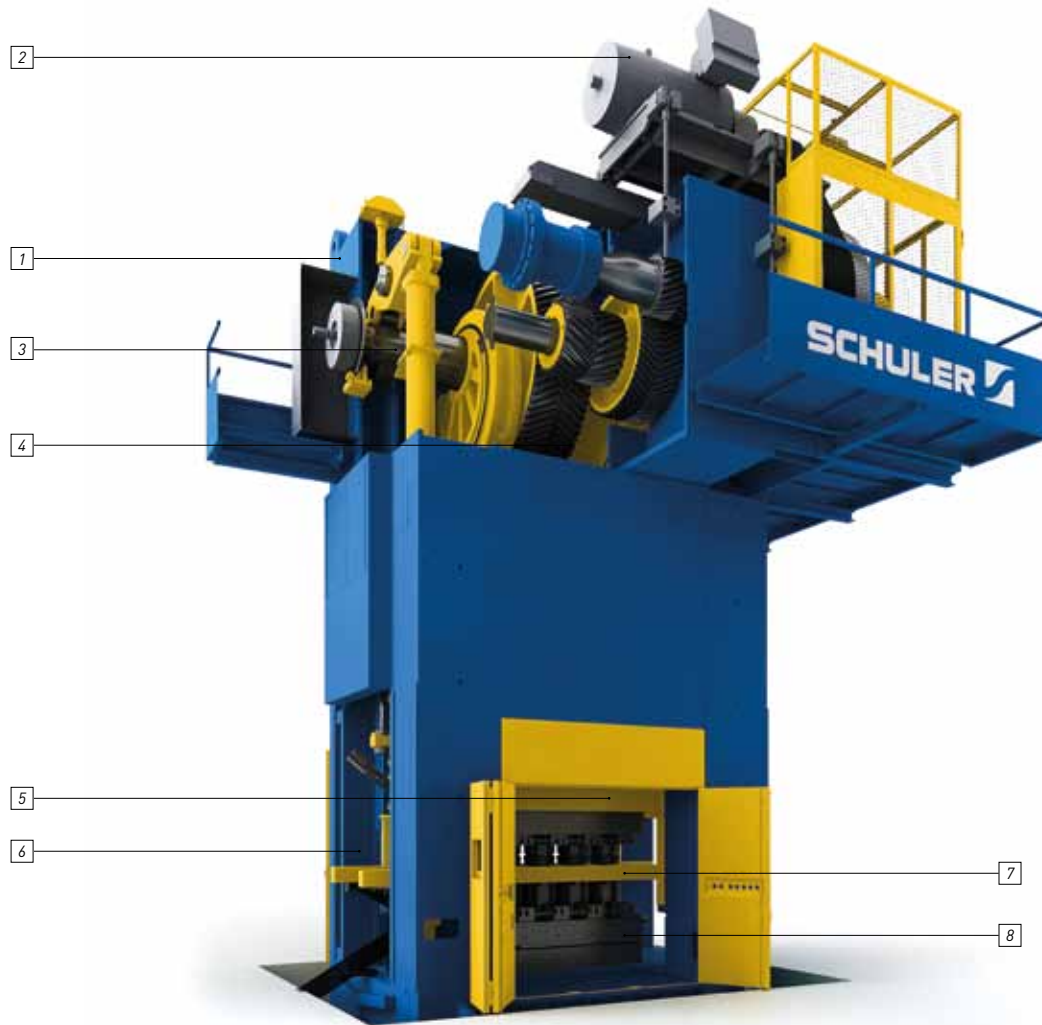

ECCENTRIC DRIVE PRESS

- 1 Crown
- 2 Main drive
- 3 Bed ejector with cam adjustment

- 4 Eccentric gears
- 5 Slide
- 6 Upright

- 7 Transfer
- 8 Die set

THE MME 2 SERIES DRIVE SYSTEM. PRECISION FORCE DELIVERED.

The MME 2 press series has been optimized for performance and impresses with extraordinary quality for the most demanding challenges.

THE DRIVE SYSTEM – FORCE DELIVERED PRECISELY WHERE NEEDED.

The eccentric drive developed by Schuler for the MME/MSE requires significantly less space than conventional multi-part eccentric gears. This permits a more compact and thus more rigid press design.

Short contact times can be achieved by means of the steep kinematics of the drive's mechanical system. This increase the service life of the tools used in warm forging and precision forging. Long parts can be produced in high volume in the automatic operating mode since the motion characteristics leave sufficient time for reliable part transport.

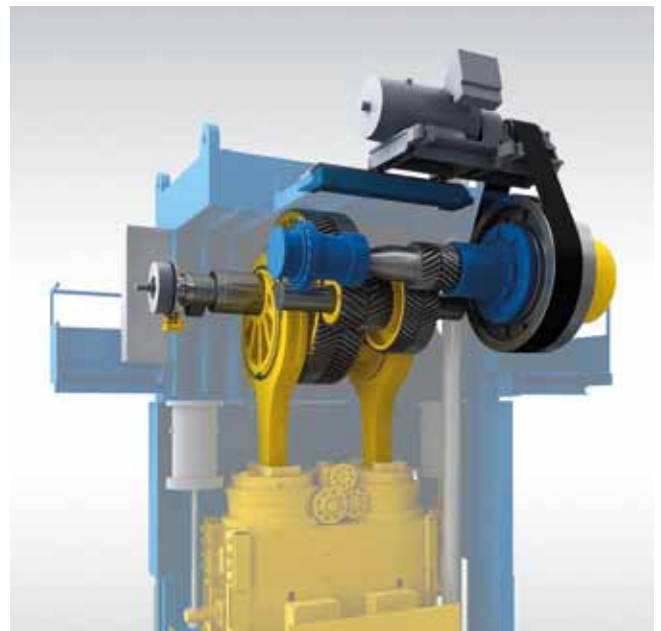

Eccentric drive system of the MME press series.

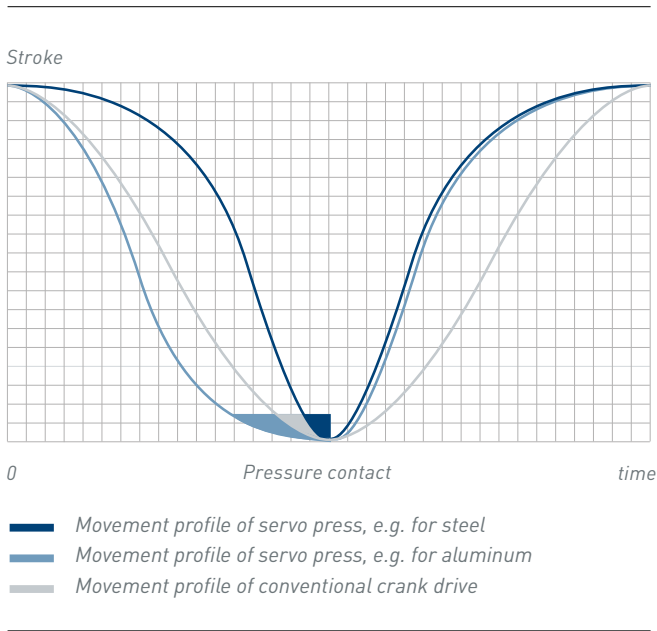

The ServoDirect Technology permits individual programming of the slide motion.

SERVO DRIVE – MSE SERIES

The combination with a servo drive extends the advantages of this drive concept even further – without limiting its possibilities compared to conventional drives. The result: highly flexible production systems with increased output rates.

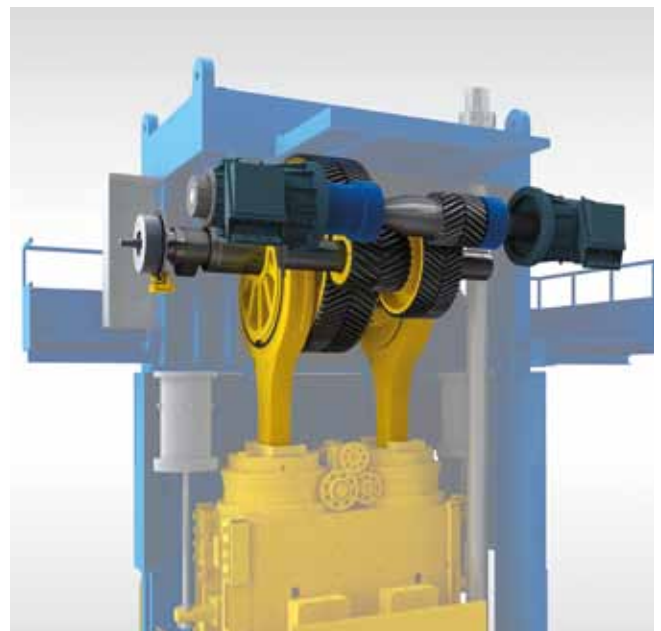

Eccentric drive system with ServoDirect Technology.

The advantages of the MSE series:

- Increased output rates
- Individually programmable ram speeds and motion sequences
- Ability to optimize the forging process
- High component quality and long die life
- Ability to adapt slide movement to the transport sequence
- Sensitive tryout operation possible
- Optimized energy consumption



Mechanical bed ejector system.

BED EJECTOR – RELIABLE TRANSPORT.

The bed ejector system of the MME/MSE series ensures reliable ejection of parts with longer shaft. In addition to the mechanical stroke, every forming station can be optionally provided with pneumatic auxiliary stroke. In this case, the ejector pin is lifted by a pneumatic cylinder. To further improve reliable part transport the auxiliary ejectors can also function as part lifting/holding devices while the mechanical ejector is completing its return stroke. A hydraulic cylinder protects the total ejector force against overload. The maximum permissible ejector force can be adjusted within certain limits.

The extraordinary operator-friendliness of the MME/MSE series is also evident in the quick, easy control of the bed ejectors.

From the operating panel it is easy to:

- Adjust the bed ejector motion curve during changeovers of the press by motorized, infinitely variable adjustment
- Store and call-up of part-dependent set-point values using the die data base
- Restart the bed ejector after clearing the cause of an overload

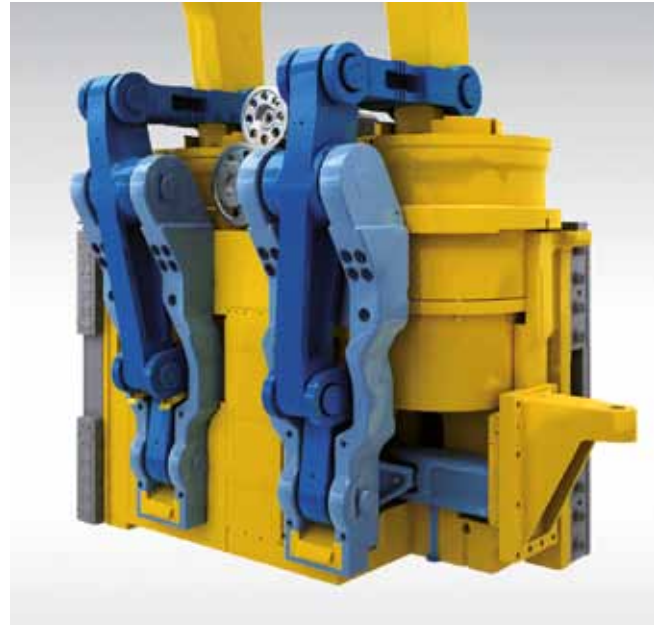

Mechanical slide ejector system.

SLIDE EJECTOR – RELIABLE EJECTION BY MECHANICAL CONNECTION .

The link system of the slide ejector is integrated into the slide and is mechanically coupled to the connecting rods that provide the ejector actuation. A lever system and a common beam transfer the ejector motion to the individual ejector pins. The design of this system provides absolutely synchronous motion sequences independent of the loading. Optional is also an as a hydraulic spring acting slide ejector possible.

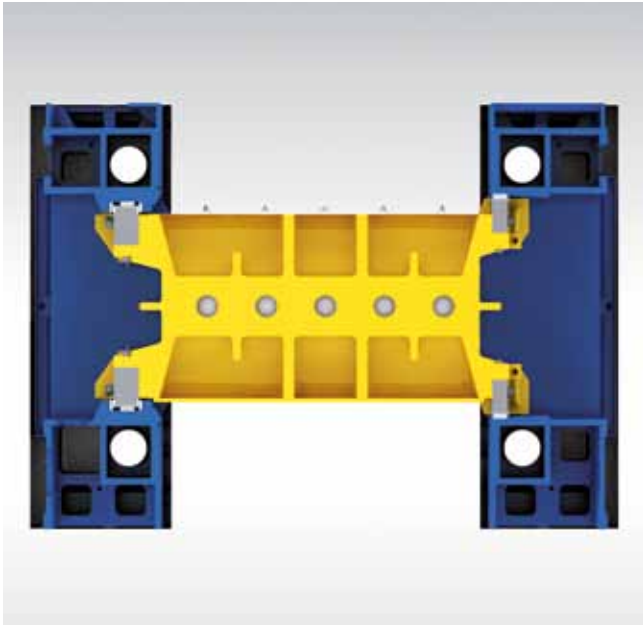

Special 8-way slide guiding in T-arrangement.

THE SLIDE GUIDING – PRECISE AND RELIABLE.

The unique Schuler 8-way slide guiding in T-arrangement works with minimal clearances.

This, in conjunction with the rigid press frame of the MME/MSE guarantees optimal part quality and tool service life. This slide guiding concept does not require additional guiding clearance in order to prevent jamming.

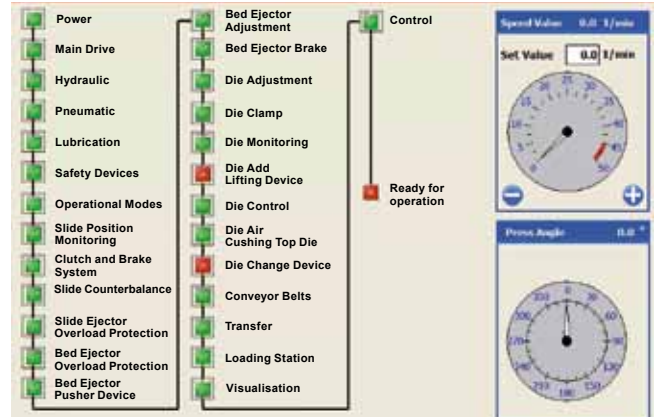

Schuler Forge Control System.

SCHULER CONTROL CONCEPT "FORGE CONTROL SYSTEM" (FCS) – MODULAR, OPEN AND EASY TO FOLLOW

With the "Forge Control System" (FCS) Schuler offers an operator-friendly and versatile software as interface to the press control. FCS provides operation, maintenance, and fault diagnostics in the appropriate national language. The collection, analysis and logging of data takes place in real time.

The operator is:

- Informed about the status of the manufacturing process and the line by means of graphic displays, measured values, and status reports. In this way, problems in processing can be dealt with early on.
- Provided step-by-step guiding or prompts in all operating modes – if needed, a help system provides directions to the menu's
- Supported by extensive die data management that permits all die-relevant data to be entered, stored, and changed.

CUSTOM-MADE PRODUCTION LINES. EVERYTHING FROM A SINGLE SOURCE.

As a supplier of individual system solutions Schuler offers turnkey production lines on request also as a turn-key line. Of course including all necessary peripheral equipment.

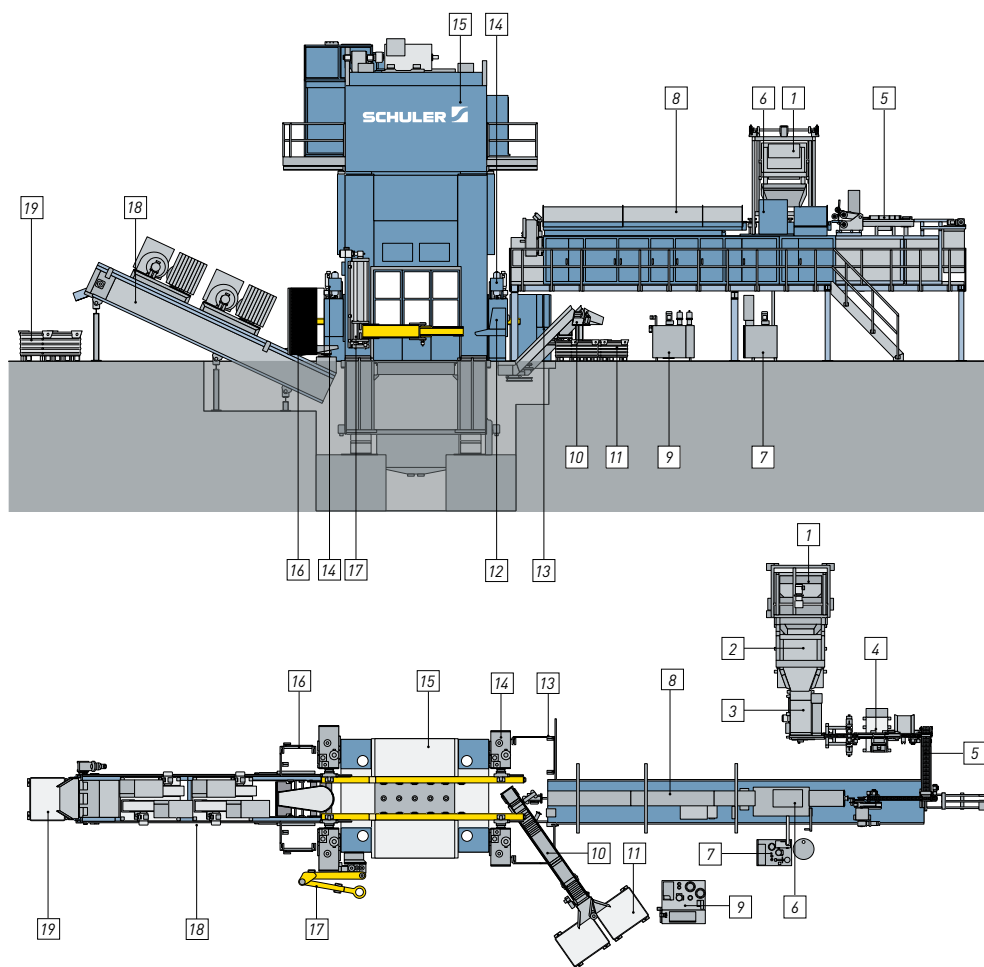

- | | | | |
|-----------------------------|-------------------------------------|---|---------------------------------------|
| 1 Bin tipper | 7 Graphite tank | 12 Operating panel | 16 Protective device on the exit side |
| 2 Vibration hopper | 8 Induction heating | 13 Protective device on the infeed side | 17 Die change arm |
| 3 Step feeder | 9 Die lubrication tank | 14 Transfer system | 18 Cooling section |
| 4 Scale with sorting device | 10 Conveyor for colder part removal | 15 Press | 19 Finished parts container |
| 6 Pre-graphitizing station | 11 Container for colder parts | | |

TECHNICAL DATA OF THE MECHANICAL MULTI-STATION PRESSES WITH ECCENTRIC DRIVE MME/MSE

Model	MME2/ MSE2 -800	MME2/MSE2 -1000	MME2/MSE2 -1200	MME2/MSE2 -1600	MME2/MSE2 -2000	MME2/MSE2 -2000	MME2/MSE2 -2000	MME2/MSE2 -2000	MME2/MSE2 -2000
Nominal force [kN]	8,000	10,000	10,000	12,000	12,000	16,000	16,000	20,000	20,000
Nominal force distance BDC [mm]	15	15	15	12	12	15	15	10	10
Slide stroke [mm]	400	500	630	500	630	630	800	630	800
Work capacity [kJ]	140	280	280	300	300	420	420	500	500
Stroke rate, adjustable [1/min]	20–50	20–45	18–38	20–45	18–38	18–40	20–38	18–40	20–38
Die height [mm]	1,160	1,360	1,360	1,360	1,360	1,600	1,600	1,600	1,600
Slide adjustment [mm]	–	–	–	–	–	10	10	25	25
Bed area Width [mm]	1,250	1,500	1,500	1,500	1,500	2,300	2,300	2,300	2,300
Depth [mm]	710	850	850	850	850	1,000	1,000	1,000	1,000
Bolster plate thickness [mm]	160	200	200	200	200	250	250	250	250
Slide area Width [mm]	1,250	1,500	1,500	1,500	1,500	2,300	2,300	2,300	2,300
Depth [mm]	710	850	850	850	850	1,000	1,000	1,000	1,000
Bed ejector force Total [kN]	500	800	800	800	800	1,200	1,200	1,200	1,200
Per station [kN]	200	375	375	375	375	600 (400)	600 (400)	600 (400)	600 (400)
Bed ejector travel [mm]	100	200	200	200	200	200	200	200	200
Slide ejector force Total [kN]	125	300	300	300	300	480	480	480	480
Per station [kN]	50	120	120	120	120	240	240	240	240
Slide ejector travel [mm]	76	86	110	86	110	135	140	135	140
Motor capacity [kW]	130	210	210	210	210	300	250	360	360

SCHULER SERVICE – STATE-OF-THE-ART SERVICE FOR MORE PERFORMANCE

Schuler Service offers a tailored portfolio of services covering the entire life cycle of your equipment. Over 900 service employees worldwide provide expert support 24/7 in close cooperation with you – our partners. Our main priority is always to ensure the maximum productivity and safety of your production equipment in order to secure your company's continued success.

Find out more. www.schulergroup.com/service_en



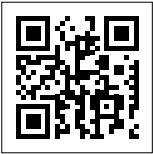

www.schulergroup.com/forging

For more information, simply scan the QR code with the camera of your smartphone or tablet.

Schuler Pressen GmbH

Bahnhofstraße 41

73033 Göppingen

Germany

Phone Sales +49 7161 66-307

Phone Service +49 7161 66-628

Fax +49 7161 66-729

forging@schulergroup.com

www.schulergroup.com/forging

