

FORMING THE FUTURE



## SERVO ECCENTRIC PRESS MSE

---

**SCHULER** 

Member of the ANDRITZ GROUP

# QUICK, POWERFUL AND GENTLE ON TOOLS. ECCENTRIC PRESSES WITH SERVO DIRECT TECHNOLOGY.

**Schuler forging.** System solutions from Schuler offer customers worldwide a decisive advantage when it comes to quality, in all temperature ranges:

- Systems for hot forging
- Systems for warm forging
- Systems for cold forging

Automated presses for solid forging are in use since 1960s with various drive concepts. Presses with ServoDirect Technologies are used successfully since many years in sheet forging as well as in solid forging applications.

ServoDirect Technology means that the existing frequency-controlled, three-phase motor with a constant speed is replaced with highly dynamic torque servo motors. The systems work without flywheel and clutch as well as brake are also dropped. The main advantage of the servo drive technology is that they provide programmable slide kinematics. This allows in achieving higher production rates, compared to conventional presses.



MSE2-2000-2.4-630.

## Reliable and flexible – eccentric presses in solid forging.

Servo presses with eccentric drive from Schuler are mainly used in warm forging. The presses of MSE series are optimized with regard to setup time and net output and are characterized by outstanding component quality so that they are suitable for demanding challenges.

Thus, the user can enjoy the benefits such as cost reduction, improved output and significant amount of flexibility.

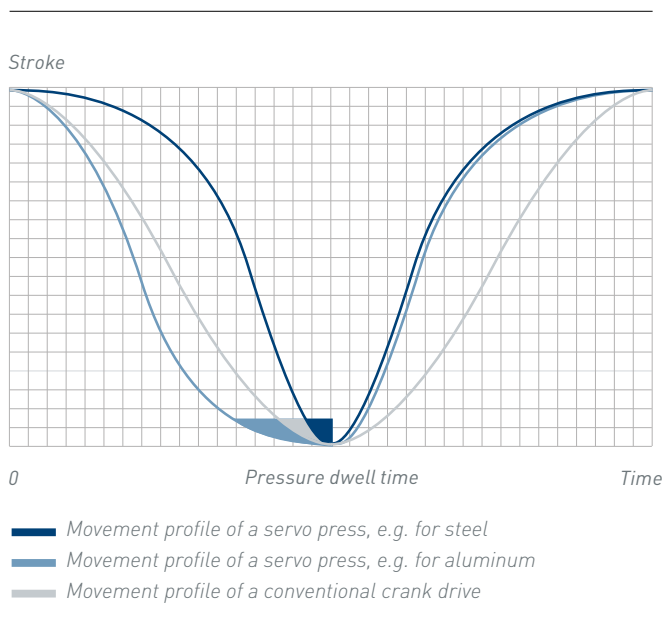

The ServoDirect Technology provides individual programming of the slide movement.

**Flexible production system.** This press type is especially suitable for long components, which have higher power requirements due to their long forging path. The combination of the eccentric drive with ServoDirect Technology provides improved production rates, because slide kinematics can be adjusted optimally to automation.

## YOUR BENEFITS

- High production speed
- Optimal quality
- Wide parts spectrum
- Minimal pressure contact times
- Prolonged idle times for die cooling
- Long die service life
- Larger die installation space
- Lower component tolerances and high component quality
- Optimized slide curves for increasing stroke rate when compared to conventional press drives



Drive of MSE press with four torque servo motors.

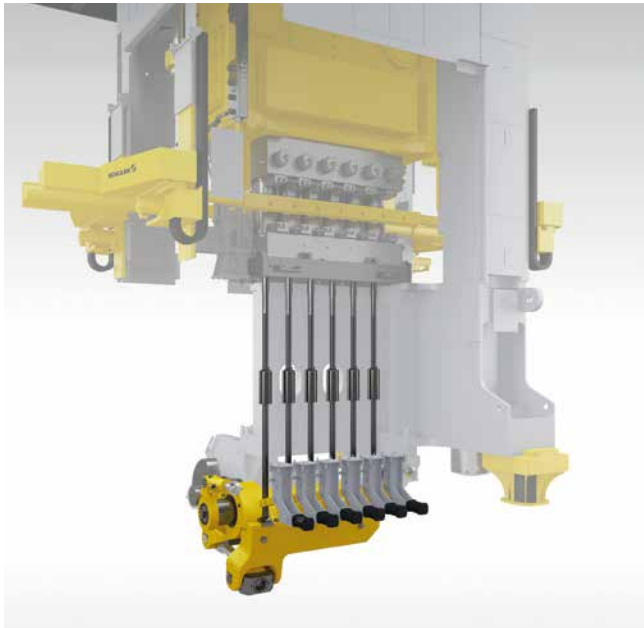

Bed ejector system with servo motor drive.

#### THE BED EJECTOR – HIGH TRANSPORT SAFETY AND COMFORTABLE OPERATION.

**Reliable transport.** The bed ejector system of MSE Series also ejects workpieces with longer shaft. The ejector movement can be adjusted precisely with the servo motor drive. Additional pneumatic lifter (option) provides individual »holding« of the individual step ejector so that an optimal parts transport is possible. A hydraulic cylinder secures the entire ejector force against overload. The maximum permissible ejector forces can be adjusted within a specific thresholds.

Extraordinary operating comfort of the MSE Series is also evident in quick and easy control of the bed ejector adjustment.

The start and end angle of the ejector movement specified based on curve can be optimized and changed from the control panel. Likewise, the bed ejector can be made operational again automatically after overload.

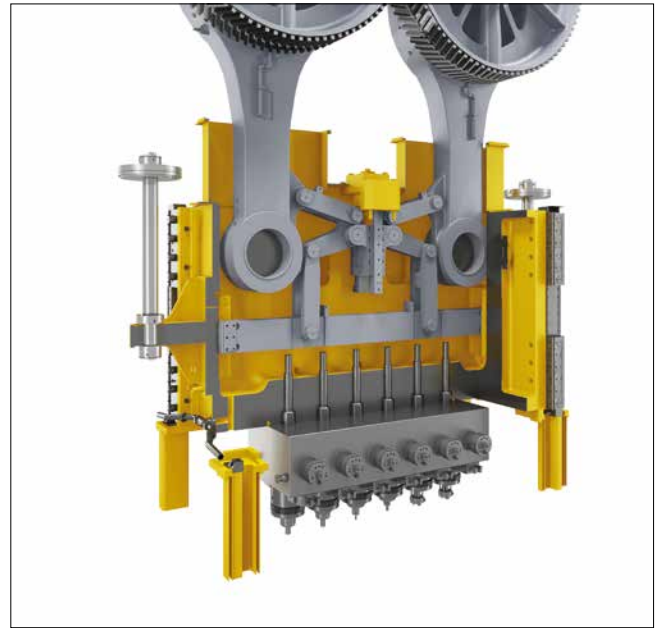

Slide ejector.

#### THE SLIDE EJECTOR - SAFE EJECTION THROUGH MECHANICAL COUPLING.

**Improved precision.** The joint system of the slide ejector integrated in the slide is connected mechanically with connecting rods and driven these rods. The ejector movement is transferred to the individual ejector pins via a lever system and a common crossbeam. This design guarantees – irrespective of load – absolutely synchronous movements. Optionally a slide ejector with spring mechanism is also possible. The slide ejector is equipped with a hydraulic overload protection for protecting the machine.

#### THE SLIDE GUIDING – PRECISE AND SAFE.

Special Schuler 8-track slide guiding in T-arrangement works with minimum clearance. In conjunction with high press rigidity of MSE, it guarantees optimal workpiece quality and workpiece service life. With this guiding concept there is no need for additional guiding play to prevent jamming.

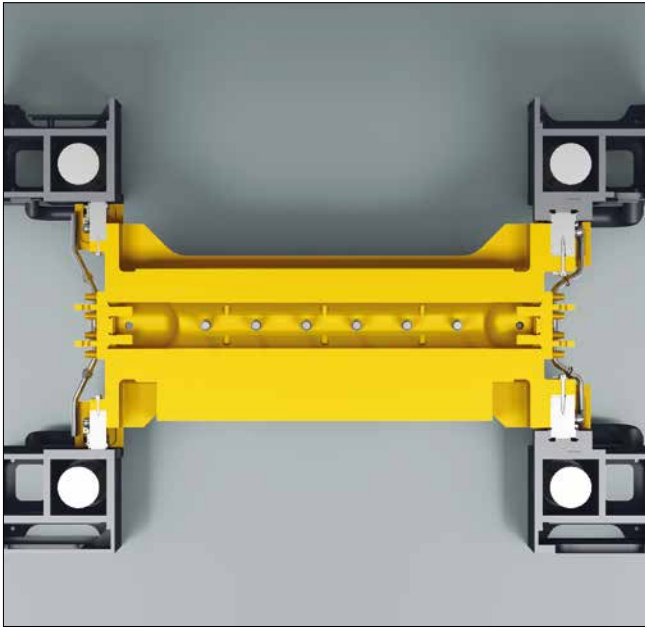

Special 8-track slide guiding in T-arrangement.

### SCHULER-CONTROLLER CONCEPT, OPEN AND CLEAR.

The Schuler visualization provides an user-friendly and flexible operator interface to the operator as interface for press control. FCS is used for operation, maintenance and error diagnosis in local language. Data collection, evaluation and logging is done in real time.

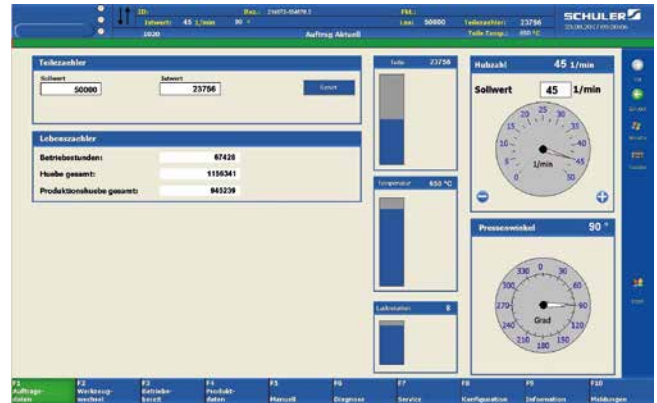

Schuler visualization.

### The operator is:

- informed about the status of the production process and the system through graphics, measurement values and state variables. Process disruptions can be handled in advance.
- is supported step wise in the process for all operating modes – a help system provides information about the menus if needed.
- is supported through a comprehensive die data management which enables the operator to save and change all data die-relevant data.

### SDT SERVO PRESSES AND 3-AXIS TRANSFER OPTIMIZER

Easy to use servo curve generator on the production system for die-specific SDT servo presses and 3-axis transfer movement sequences.

#### Main features:

- Access to program tool for generating flexible movement profiles for a SDT servo press and a 3-axis transfer system
- Expert mode for freely programmable SDT movement sequences and selectable templates, which can be adjusted in terms of stroke rates and forging speed
- Due to flexible programming, maximum part-specific increase in output rates within the machine thresholds
- Implemented in the visualization of the machine controller
- Various analysis function and display of movement and free movement curves

# CUSTOMIZED PRODUCTION LINES. EVERYTHING FROM A SINGLE SOURCE.

As provider of custom system solutions, Schuler also offers production lines as turn-key solution on request – naturally inclusive of all the required peripheral equipment.

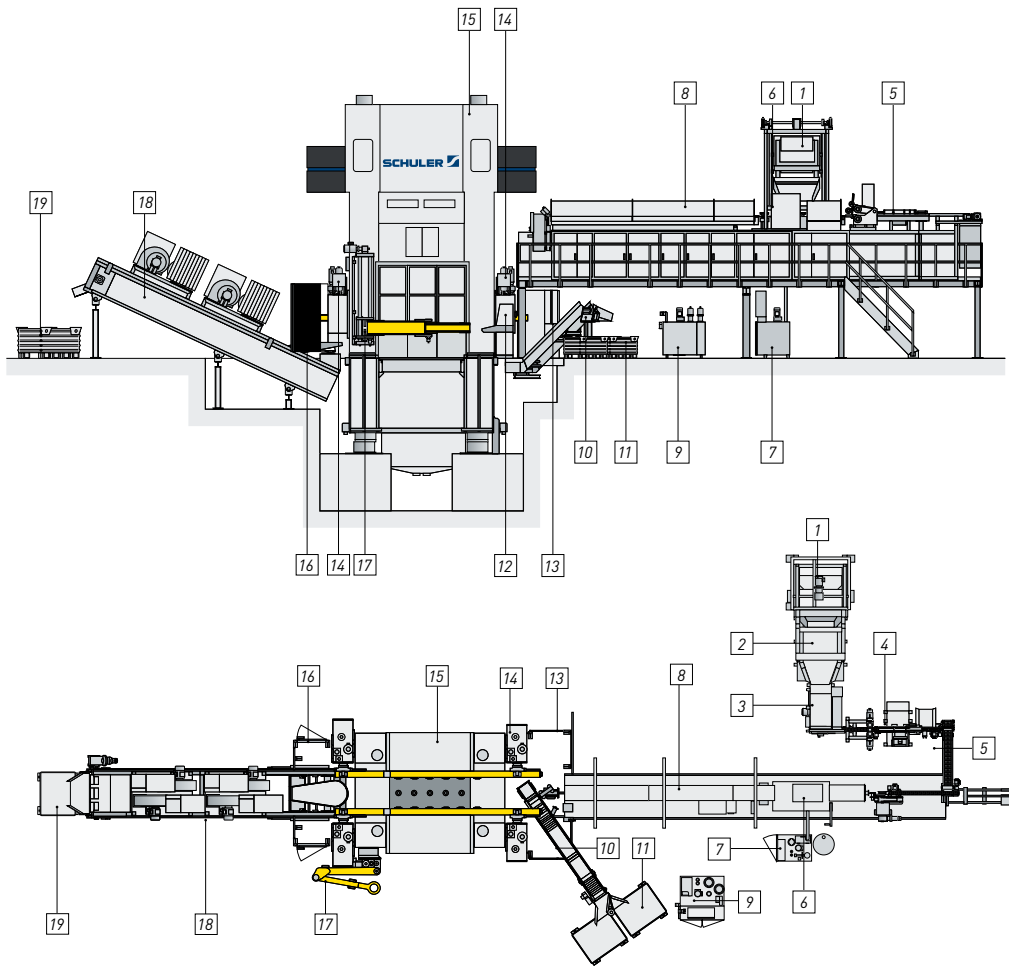

- |                        |                                  |                                 |                             |
|------------------------|----------------------------------|---------------------------------|-----------------------------|
| 1 Box tipper           | 7 Container for pre-graphitizing | 12 Control panel                | side                        |
| 2 Vibration bunker     | 8 Induction heating              | 13 Safety device on the infeed  | 17 Die removal aid          |
| 3 Step conveyor        | 9 Container for die lubrication  | side                            | 18 Cooling section          |
| 4 Scale with ejection  | 10 Exit conveyor belt            | 14 Transfer device              | 19 Finished parts container |
| 5 Cross transport belt | for cold parts                   | 15 Press                        |                             |
| 6 Pre-graphitizing     | 11 Container for cold parts      | 16 Safety device on the outfeed |                             |

## TECHNICAL DATA OF MECHANICAL MULTI-STEP PRESSES WITH ECCENTRIC DRIVE MME/MSE

Model	MSE2-800	MSE2-1200	MSE2-2000
Nominal press capacity [kN]	8,000	12,000	20,000
Rated duty stroke before forging Forging	8	10	8
Rated duty stroke before forging Forging	15	12.5	10
Slide stroke [mm]	400	500	630
Working capacity [KJ]	200	300	400
Stroke rate, adjustable [1/min]	55	50	45
Die installation height [mm]	1,160	1,360	1,590
Slide adjustment [mm]	10	10	10
Bed surface width [mm]	2,000	2,200	2,400
Depth [mm]	1,000	1,000	1,000
Clamping plate thickness [mm]	160	200	250
Slide surface width [mm]	2,000	2,200	2,400
Depth [mm]	1,000	1,000	1,000
Total bed ejector force [kN]	500	800	1,100
per level [kN]	200	375	600
Bed ejector path [mm]	200	200	200
Total slide ejector force [kN]	300	300	480
per level [kN]	120	120	240
Slide ejector path [mm]	85	85	140
Drive output [kW]	2×503	3×503	4×503

Subject to technical modifications.

### SCHULER SERVICE – STATE-OF-THE-ART SERVICE FOR MORE PERFORMANCE

Schuler Service offers a tailored portfolio of services covering the entire life cycle of your equipment. Over 900 service employees worldwide provide expert support 24/7 in close cooperation with you – our partners. Our main priority is always to ensure the maximum productivity and safety of your production equipment in order to secure your company's continued success.

Find out more. [www.schulergroup.com/service\\_en](http://www.schulergroup.com/service_en)



## ABOUT THE SCHULER GROUP – [WWW.SCHULERGROUP.COM](http://WWW.SCHULERGROUP.COM)

Schuler is the world market leader in metal forming technology. The company supplies presses, automation solutions, dies, process know-how, and services for the entire metalworking industry and lightweight automotive design. Customers include automobile manufacturers and suppliers as well as companies from the forging, household appliances, packaging, energy, and electronics industries. Schuler is the leading supplier of minting presses and supplies system solutions for aerospace, rail transport, and large pipe manufacturing. Following the acquisition of toolmaker AWEBA and a majority stake in Chinese press manufacturing company Yadon, Schuler employs around 6,600 members of staff in 40 countries. The Austrian ANDRITZ Group holds a majority share in Schuler.

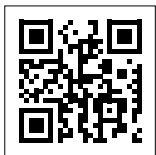

[www.schulergroup.com/forging](http://www.schulergroup.com/forging)

### Schuler Pressen GmbH

Bahnhofstraße 41

73033 Göppingen

Germany

Phone Sales +49 7161 66-307

Phone Service +49 7161 66-628

Fax +49 7161 66-729

[forging@schulergroup.com](mailto:forging@schulergroup.com)

[www.schulergroup.com/forging](http://www.schulergroup.com/forging)

