

Sheet Metal Forging

New Process: Hot Forming Gears



Forming the future

SHEET METAL FORGING: GEARS

Stronger Gear Structure

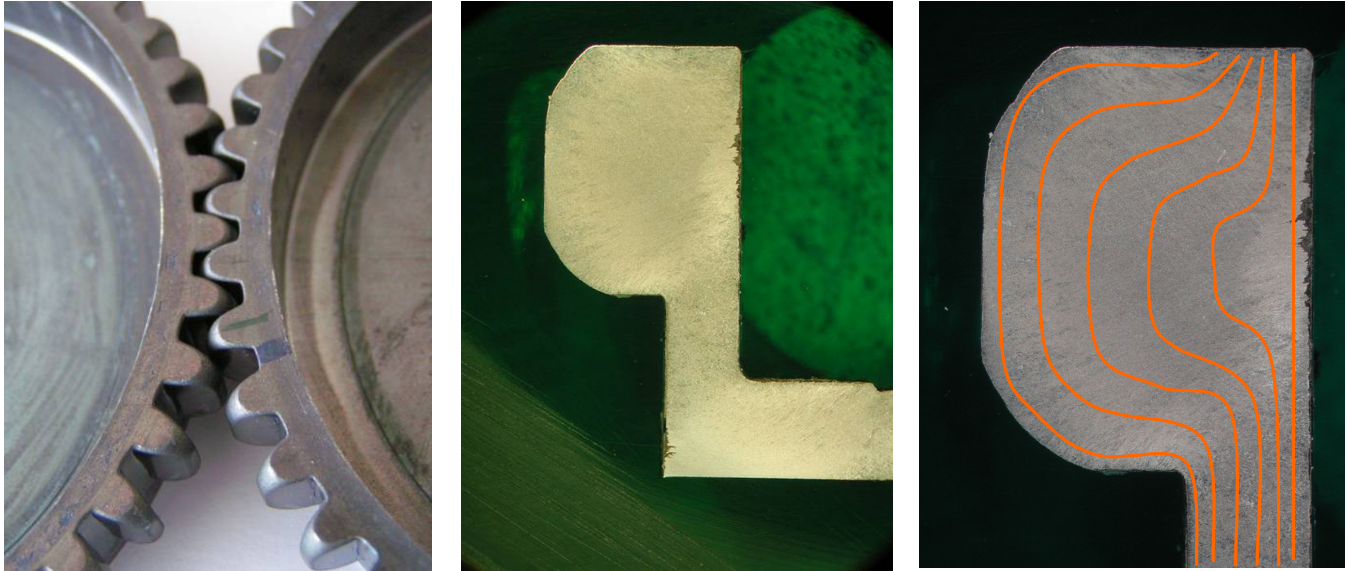

Advantage: Sheet metal forging provides constant grain structure, with no overlap.

Full Manufacturing Process in a Transfer Press

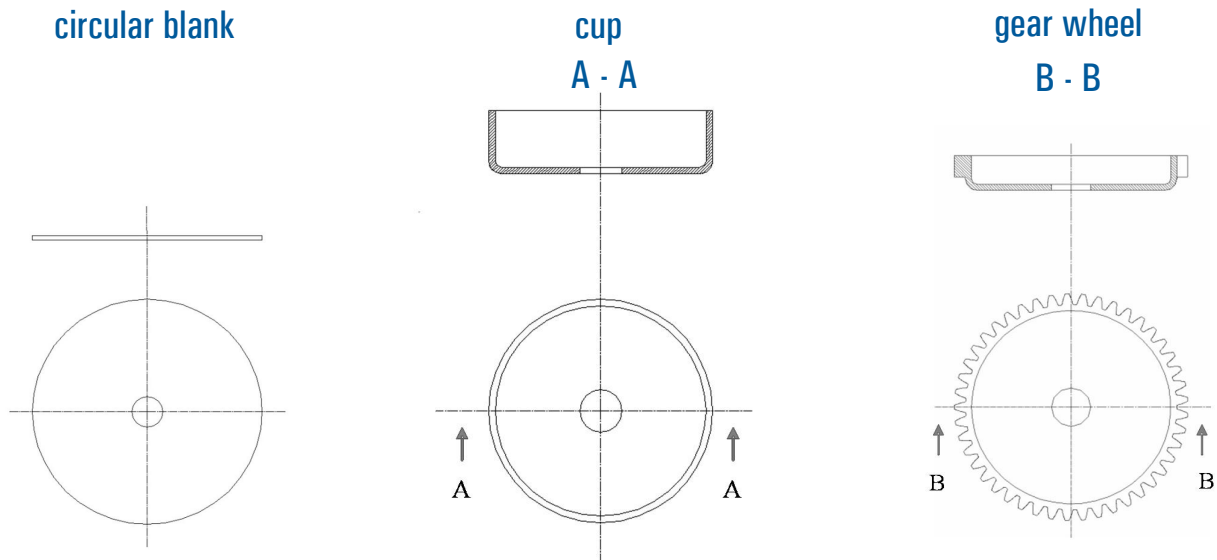

NEW PROCESS ADVANTAGES

- Faster manufacturing process
- 25% reduction in manufacturing cost
- Lighter weight

SCHULER INCORPORATED

7145 Commerce Blvd. | Canton, Michigan 48187 | USA
 Phone (734) 207-7200 | Fax (734) 207-7260
 E-mail: info@schulerinc.com | www.schulerinc.com